

2



1

### PARTS LIST

ITEM	PART #	DESCRIPTION	NOTES
1	K1391/92	Series 4 SF Access Body / Bleed Cover	Assembly
2	1200	Series 2/3/4 Reveal	Attaches to the Body
3	K1337	Series 4 Round Post	Assembly
4	5430	Series 4 Round Post Cap	3/4" Reveal Tab
41	5040	Cap Screw	#10 countersink

**NOTE: PRE-CUT KITS ARE NOT PRE-DRILLED.**

(Holes shown in this drawing are for reference only. Drilling of pilot holes are to be done by fabricator.)

### REVEAL SETTING OPTIONS

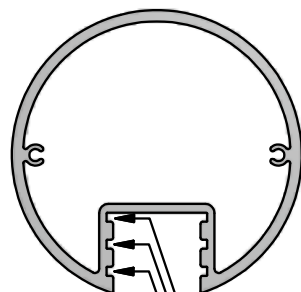

ZERO REVEAL  
3/8" REVEAL  
3/4" REVEAL

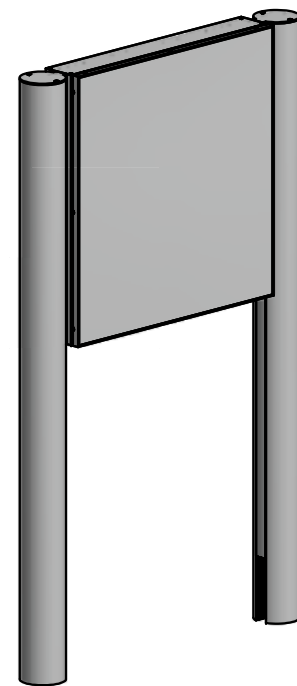

B

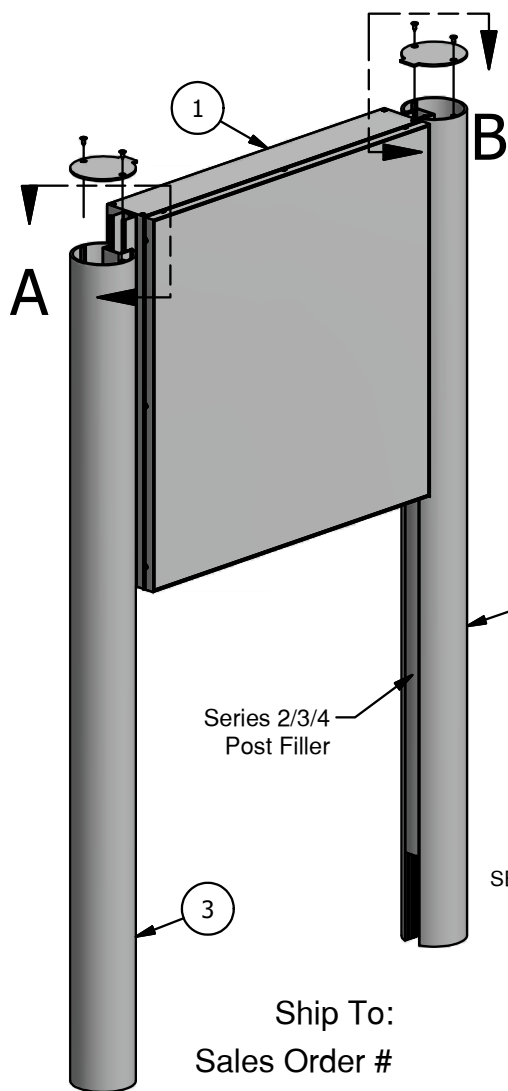

Series 2/3/4 Post Filler

Ship To:  
Sales Order #

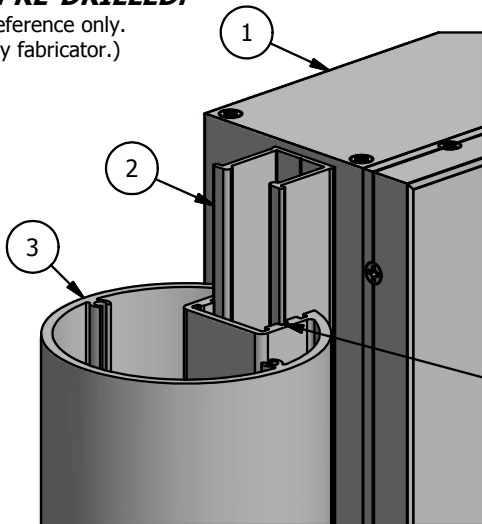

DETAIL A

SLIDE THE BODY/CABINET ASSEMBLY INTO THE DESIRED REVEAL POSITION IN THE POST.

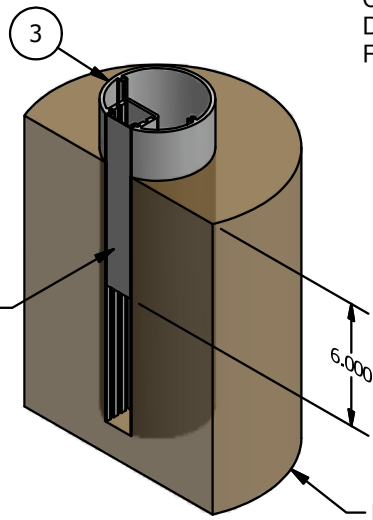

SERIES 2/3/4 REVEAL/POST FILLER IS CUT TO FIT 6" BELOW THE GRADE.

FOOTING

NOTE: THE TAB ON THE CAP IS TO BE SHEERED DOWN TO THE DESIRED REVEAL BY FABRICATOR.

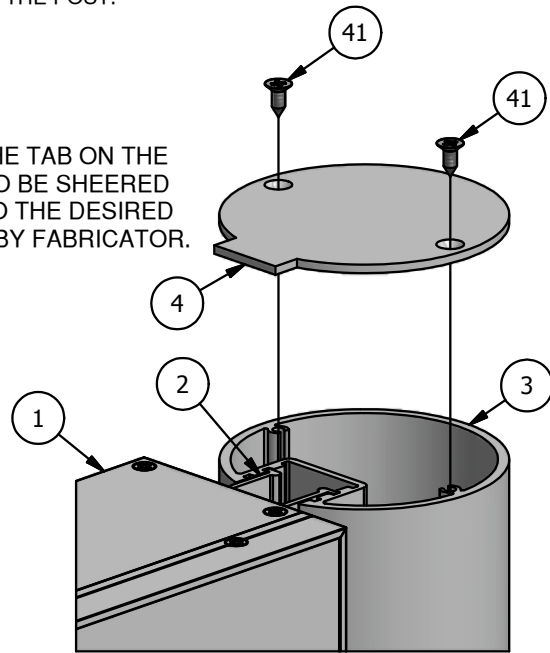

DETAIL B

2



1

THIS DRAWING WAS CREATED AT NO CHARGE TO ASSIST YOU IN VISUALIZING OUR PROPOSAL. THE DRAWING HEREIN IS THE PROPERTY OF SIGNCOMP. PERMISSION TO COPY OR REVISE THIS DRAWING OR TO USE THIS DRAWING FOR PRODUCTION IS STRICTLY PROHIBITED AND CAN ONLY BE COPIED, REVISED OR USED FOR PRODUCTION WITH THE EXPRESSED WRITTEN PERMISSION OF SIGNCOMP.

Project Name: Series 4 SF Access Body - Bleed Cvr - Series 4 Round Post - Ass  
 Sign Company: K1391/92/37  
 Revision:   
 Date: 10/30/2017  
 Sheet: 1 of 1  
 Drawing By: SBreihof  
 Size: A

# SignComp

B



A

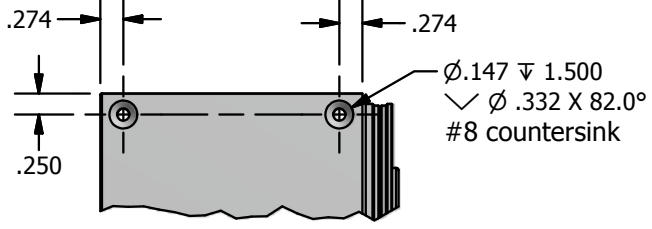

HOLE DETAIL  
DRILLED BY OTHER

PARTS LIST			
ITEM	PART #	DESCRIPTION	NOTES
1	1391	Series 4 Single Face Access Body	Top & Bottom
2	1391	Series 4 Single Face Access Body	Sides
3	5340	Series 4 Access Body Corner Angle	One (1) per body corner
5		.063 Aluminum Back	By Other
60	5270	Access Body Corner Screw	See hole detail

**NOTE: PRE-CUT KITS ARE NOT PRE-DRILLED.**  
(Holes shown in this drawing are for reference only.  
Drilling of pilot holes are to be done by fabricator.)

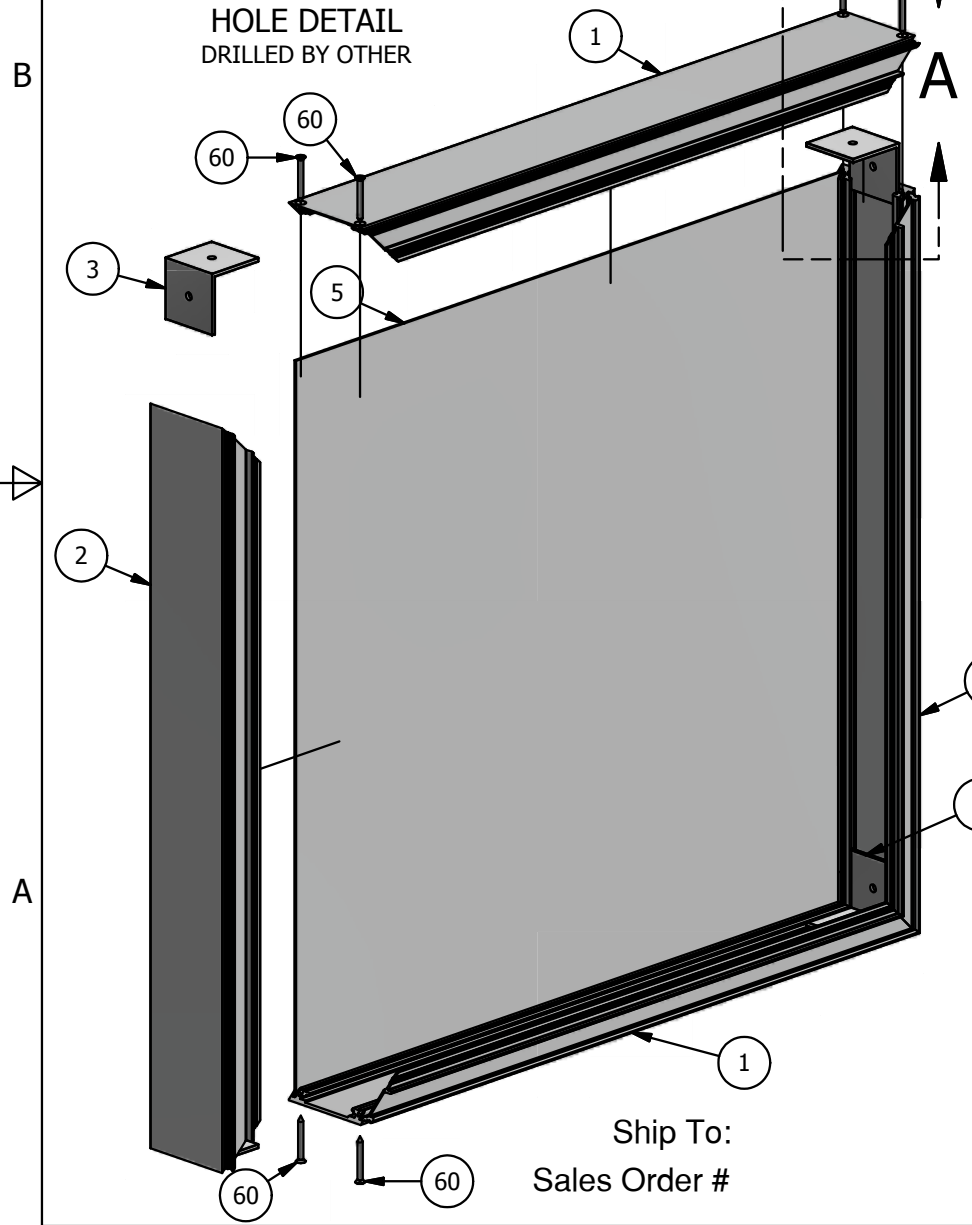

Ship To:  
Sales Order #

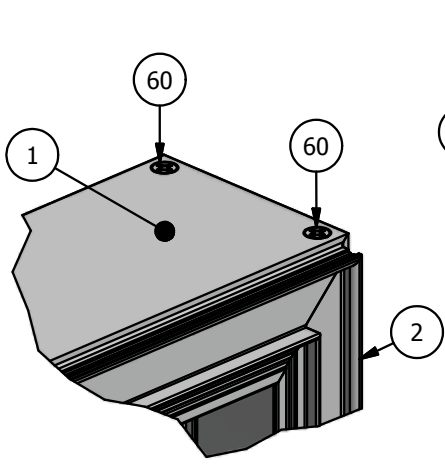

DETAIL A-2

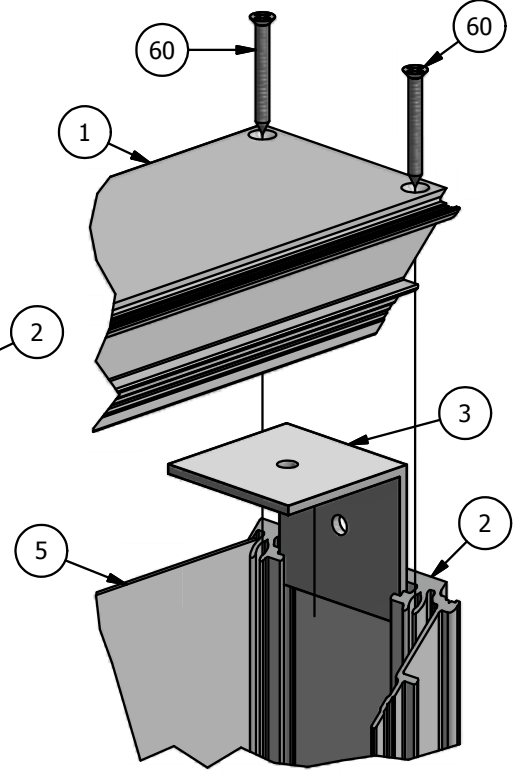

DETAIL A-1

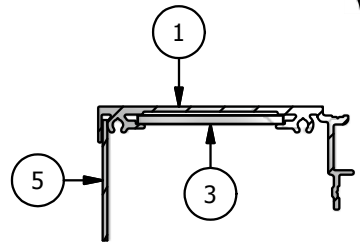

CABINET SECTION-VIEW

THIS DRAWING WAS CREATED AT NO CHARGE TO ASSIST YOU IN VISUALIZING OUR PROPOSAL. THE DRAWING HEREIN IS THE PROPERTY OF SIGNCOMP. PERMISSION TO COPY OR REVISE THIS DRAWING OR TO USE THIS DRAWING FOR PRODUCTION IS STRICTLY PROHIBITED AND CAN ONLY BE COPIED, REVISED OR USED FOR PRODUCTION WITH THE EXPRESSED WRITTEN PERMISSION OF SIGNCOMP.

Project Name: **Series 4 Single Face Access Body**  
 Sign Company: **K1391**  
 Part #: \_\_\_\_\_  
 Revision: \_\_\_\_\_  
 Date: **3/22/2017**  
 Drawing By: **SBreihof**  
 Sheet: **1 of 1**  
 Size: \_\_\_\_\_



## PARTS LIST

ITEM	PART #	DESCRIPTION	NOTES
1	K1391	Series 4 SF Access Body	Assembly
2	1692	Bleed Cover	All Sides
3	5210	Corner Key	One (1) per corner
64	5168	Frameless Cover Screw	Drill #8 countersink

**NOTE: PRE-CUT KITS ARE NOT PRE-DRILLED.**  
 (Holes shown in this drawing are for reference only.  
 Drilling of pilot holes are to be done by fabricator.)

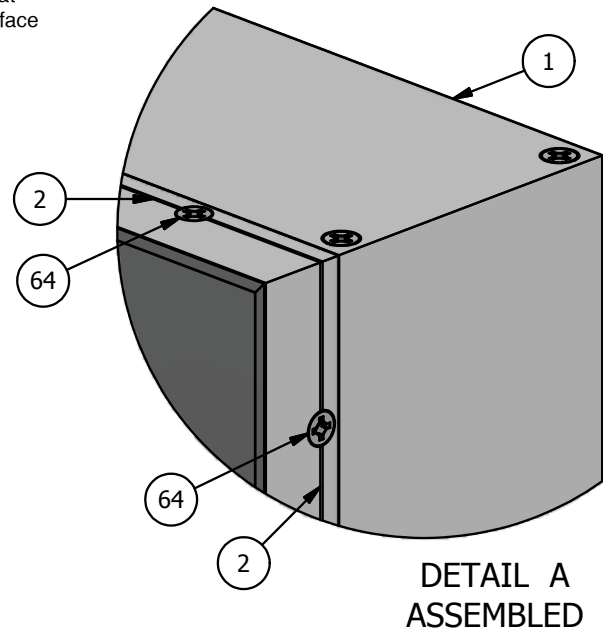
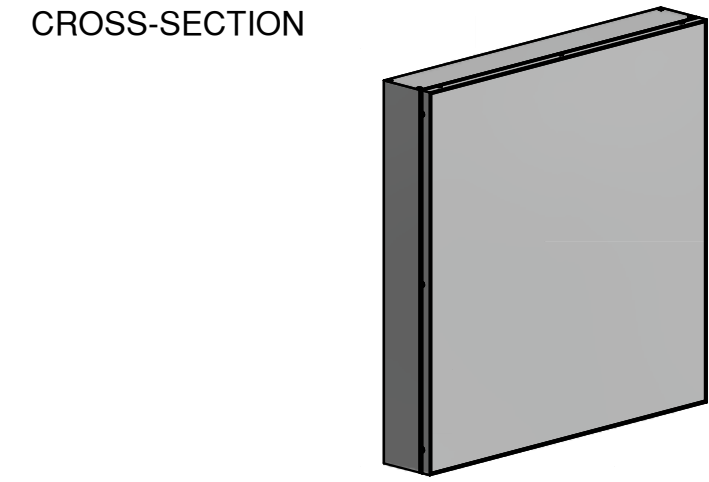
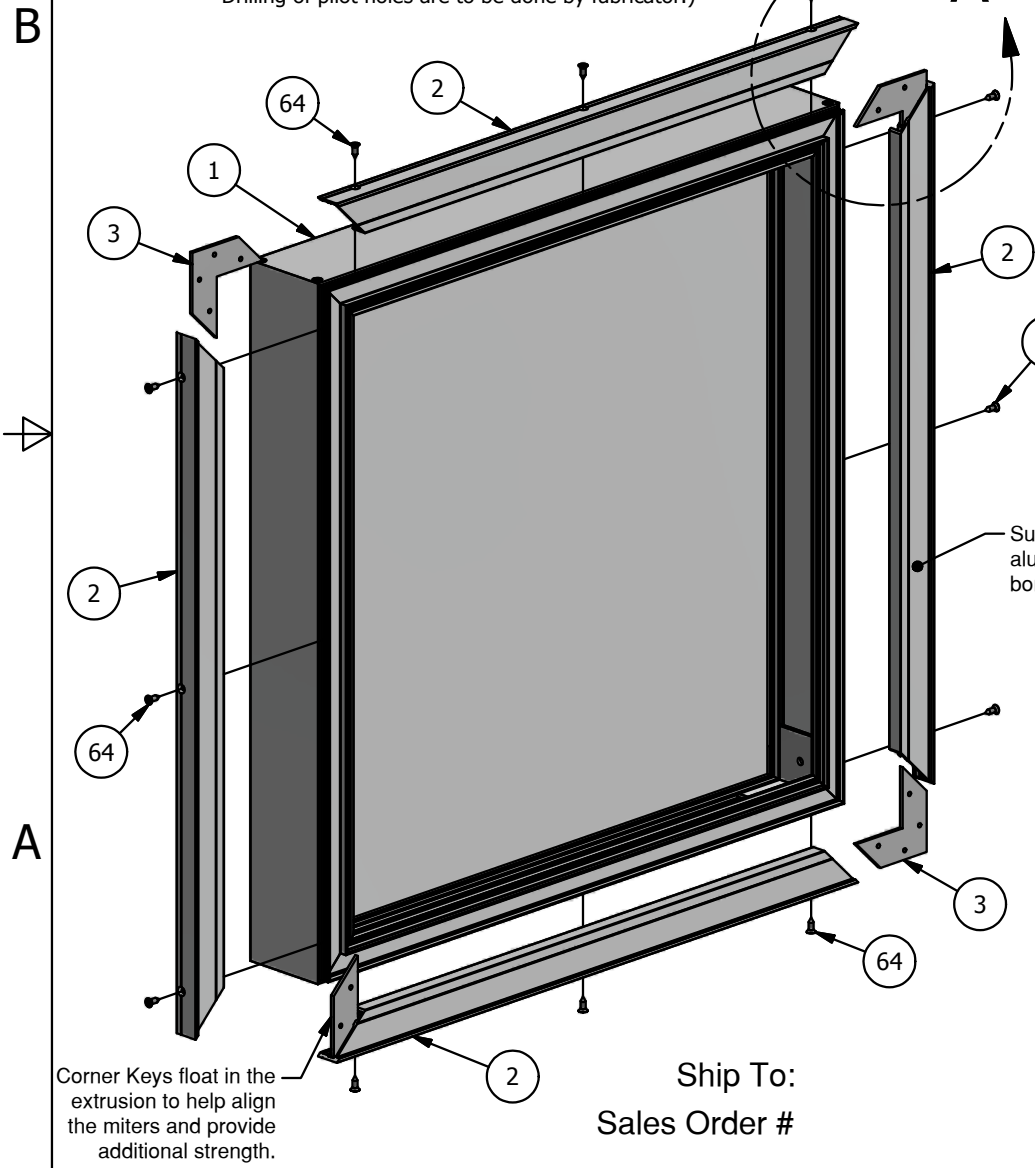
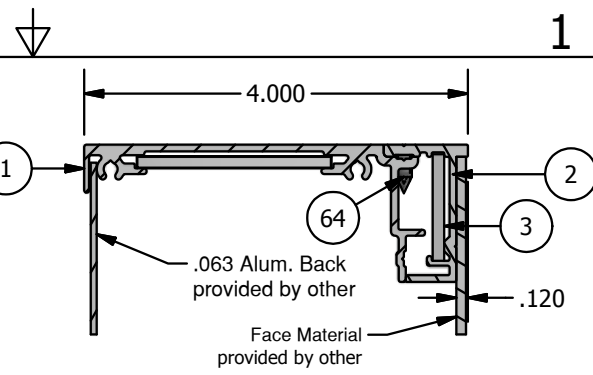

Ship To:  
Sales Order #

THIS DRAWING WAS CREATED AT NO CHARGE TO ASSIST YOU IN VISUALIZING OUR PROPOSAL. THE DRAWING HEREIN IS THE PROPERTY OF SIGNCOMP. PERMISSION TO COPY OR REVISE THIS DRAWING OR TO USE THIS DRAWING FOR PRODUCTION IS STRICTLY PROHIBITED AND CAN ONLY BE COPIED, REVISED OR USED FOR PRODUCTION WITH THE EXPRESSED WRITTEN PERMISSION OF SIGNCOMP.

Project Name:	Series 4 SF Access Body w/ Bleed Cover - Assembly
Sign Company:	K1391/92
Part #:	
Revision:	
Date:	5/9/2017
Sheet:	1 of 1
Size:	A
Drawing By:	SBreihof



## PARTS LIST

ITEM	PART#	DESCRIPTION	NOTES
1	K1391/92	Series 4 SF Access Body/Bleed Cover	Assembly
2	1200	Series 2/3/4 Reveal	
42	5218	Reveal to Body Screw	Drill 5/32" pilot hole

**NOTE: PRE-CUT KITS ARE NOT PRE-DRILLED.**

(Holes shown in this drawing are for reference only.  
Drilling of pilot holes are to be done by fabricator.)

Ship To:  
Sales Order #

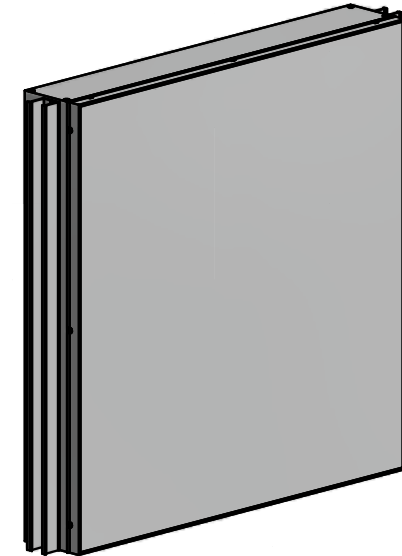
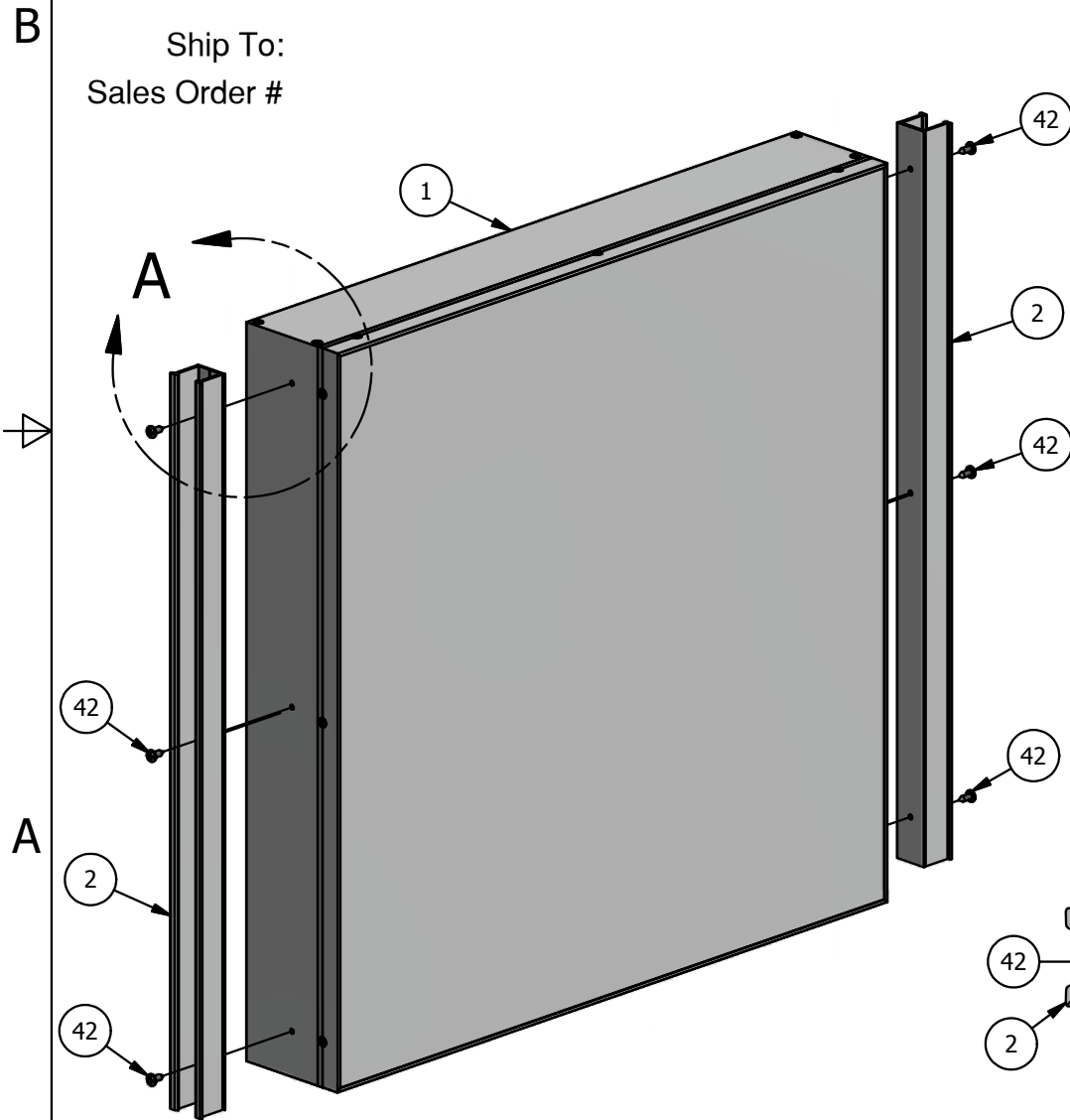

REVEAL IS FASTENED 1/8" DOWN FROM THE TOP OF THE CABINET TO ALLOW FOR THE POST CAP

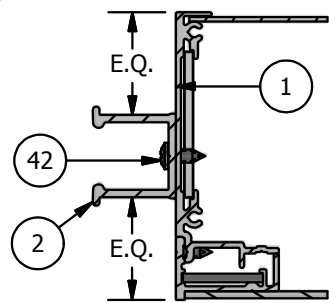
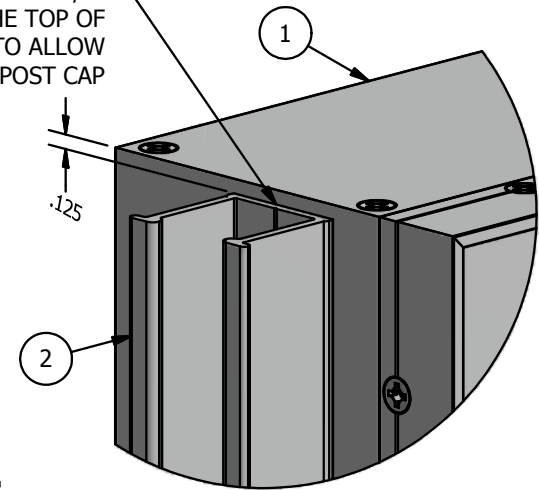

THIS DRAWING WAS CREATED AT NO CHARGE TO ASSIST YOU IN VISUALIZING OUR PROPOSAL. THE DRAWING HEREIN IS THE PROPERTY OF SIGNCOMP. PERMISSION TO COPY OR REVISE THIS DRAWING OR TO USE THIS DRAWING FOR PRODUCTION IS STRICTLY PROHIBITED AND CAN ONLY BE COPIED, REVISED OR USED FOR PRODUCTION WITH THE EXPRESSED WRITTEN PERMISSION OF SIGNCOMP.

Project Name: Series 4 SF Access Body w/ Bleed Cvr - Series 2/3/4 Reveal - Ass.	Sign Company: K1391/92 - Reveal
Sheet: 1 of 1	Part #:
Drawing By: SBreihof	Revision:
Size:	Date: 10/23/2017



PARTS LIST			
ITEM	PART#	DESCRIPTION	NOTES
1	1337	Series 4 4" Round Post	
2	1201	Series 3/4 Post Filler	Tack weld or mechanically fasten to post

D  
C  
B  
A

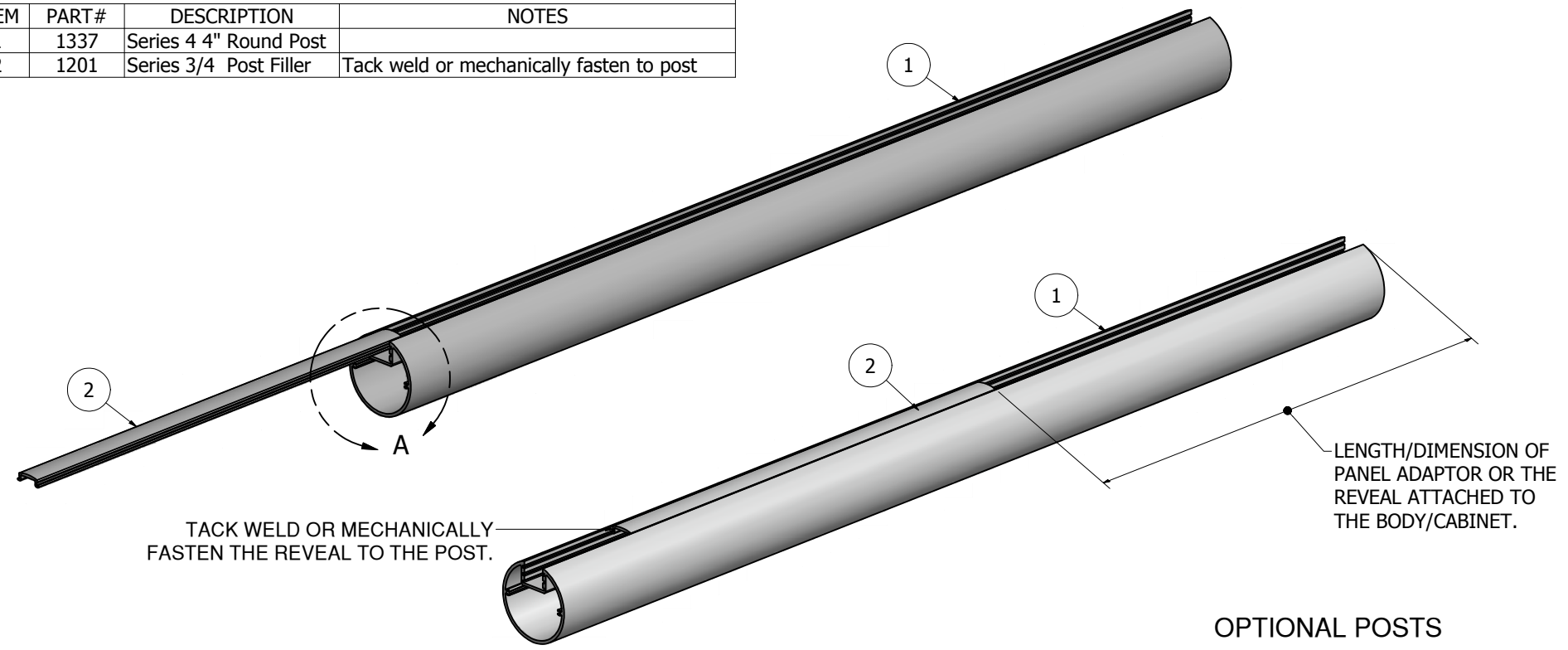

TACK WELD OR MECHANICALLY FASTEN THE REVEAL TO THE POST.

LENGTH/DIMENSION OF PANEL ADAPTOR OR THE REVEAL ATTACHED TO THE BODY/CABINET.

OPTIONAL POSTS

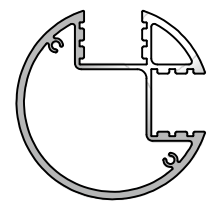

#1339  
4" ROUND 90° POST

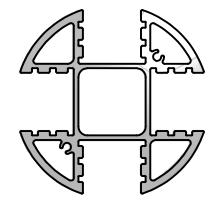

#1338  
4" ROUND 4-SIDED POST

**NOTE: PRE-CUT KITS ARE NOT PRE-DRILLED.**  
(Holes shown in this drawing are for reference only. Drilling of pilot holes are to be done by fabricator.)

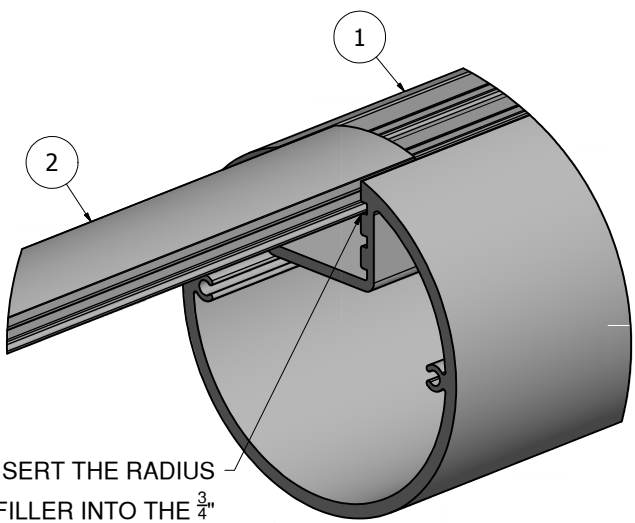

INSERT THE RADIUS FILLER INTO THE  $\frac{3}{4}$ " REVEAL POSITION THEN SLIDE IT UP INTO THE POST.

DETAIL A

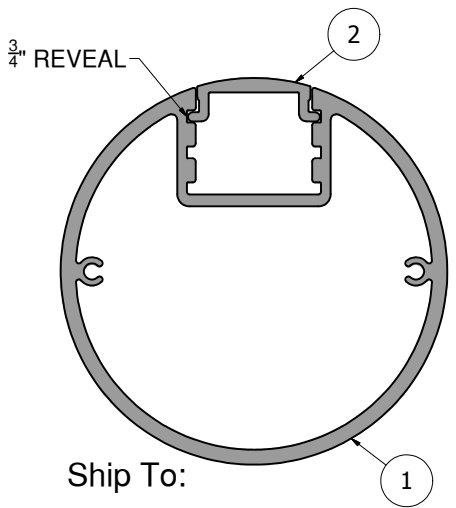

Ship To:  
Sales Order #

THIS DRAWING WAS CREATED AT NO CHARGE TO ASSIST YOU IN VISUALIZING OUR PROPOSAL. THE DRAWING HEREIN IS THE PROPERTY OF SIGNCOMP. PERMISSION TO COPY OR REVISE THIS DRAWING OR TO USE THIS DRAWING FOR PRODUCTION IS STRICTLY PROHIBITED AND CAN ONLY BE COPIED, REVISED OR USED FOR PRODUCTION WITH THE EXPRESSED WRITTEN PERMISSION OF SIGNCOMP.		
DRAWING BY:	SBreihof	4/15/2013
Centroid X:	0.000 in	TITLE
Centroid Y:	0.000 in	
Principal Moments Ix:	0.000 in <sup>4</sup>	Series 4 4" Round Post - Series 3/4 Radius Filler Assembly
Principal Moments Iy:	0.000 in <sup>4</sup>	
Section Modulus Ix:	0.000 in <sup>3</sup>	PART NO
Section Modulus Iy:	0.000 in <sup>3</sup>	<b>1337-01</b>
		REV
		SHEET 1 OF 1

4

3

2

1

4

3

2

1